

# Linking Value Chains – Combining e3Value and DEMO for specifying Value Networks

EEWC 2014

*João Pombinho, David Aveiro, José Tribolet*



INSTITUTO SUPERIOR TÉCNICO  
Universidade Técnica de Lisboa



# Problem

from Intention...

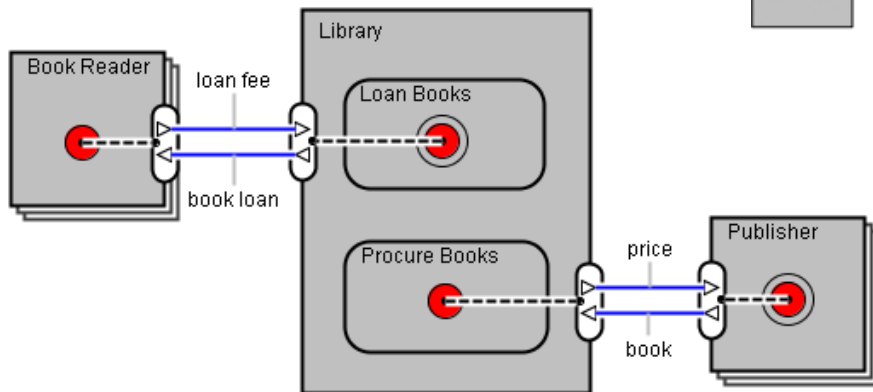

*Buy once, loan many*

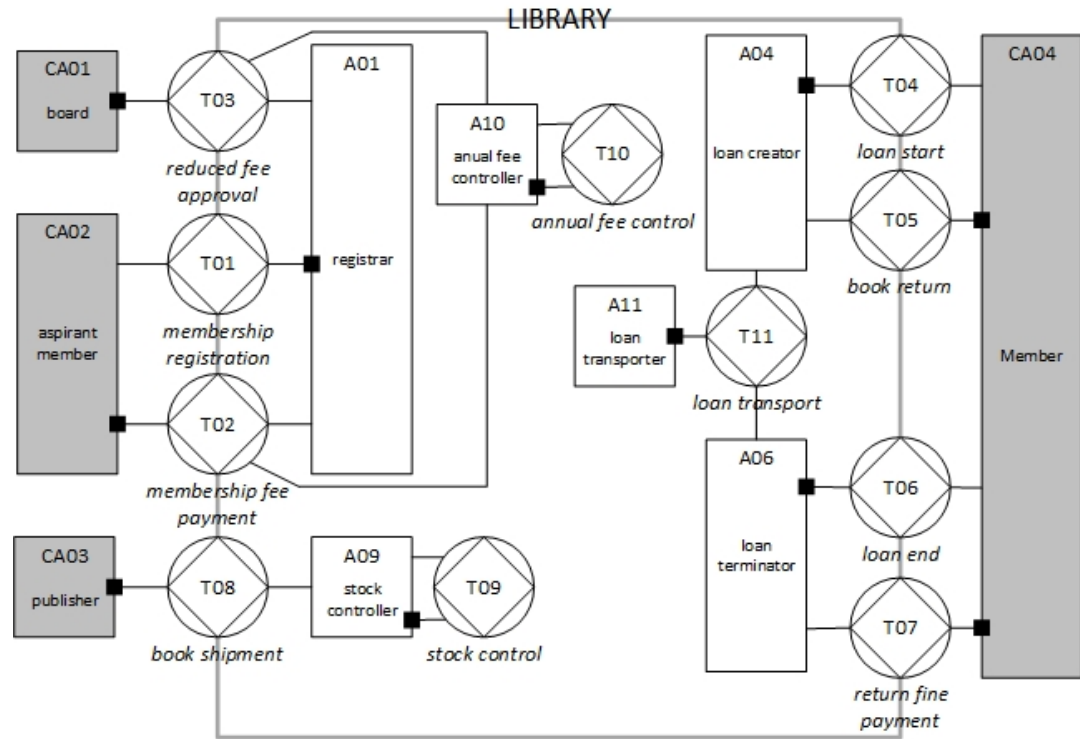

...to Construction

# Problem

Different worlds?

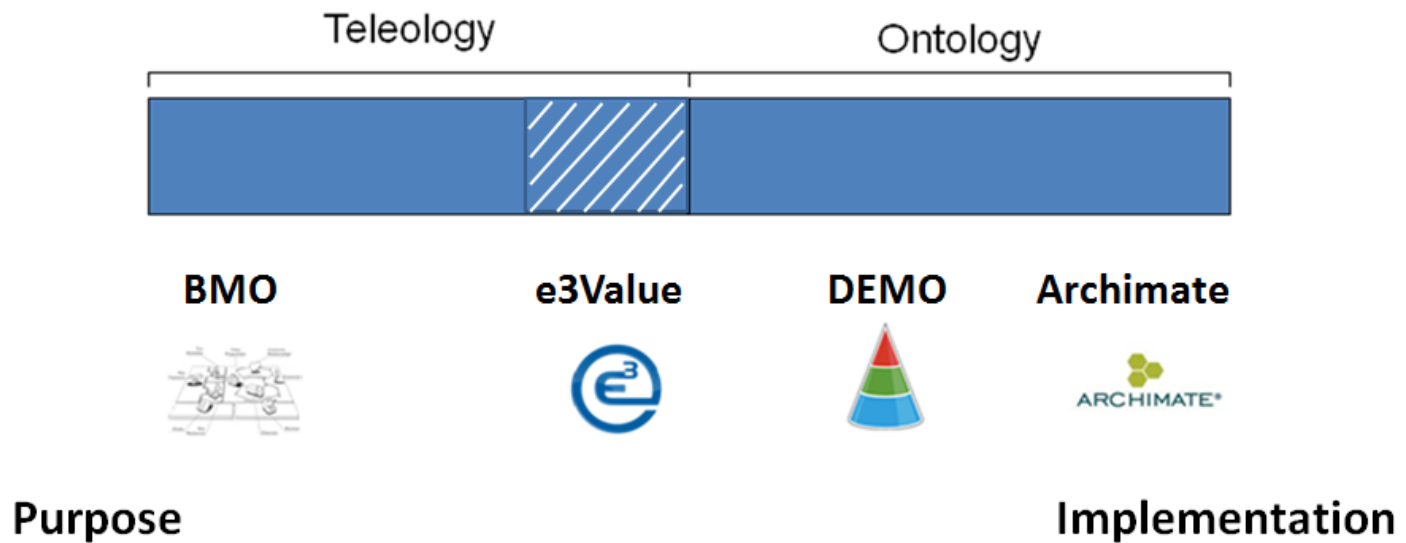

# Approach

(more) objectively model the contribution perspective through value models as a fundamental means to address configuration dynamics

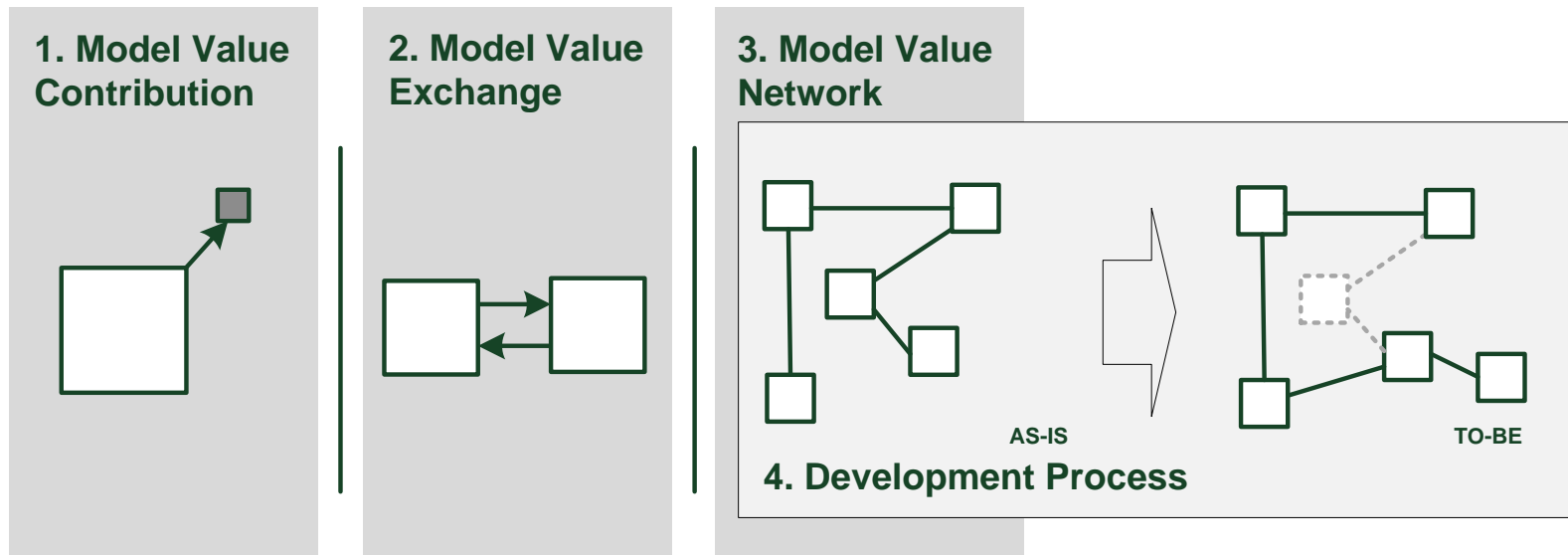

*Explaining*

+

*Changing*

# (1) Value Contribution

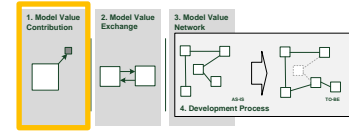

**Specifying what is the value object brought about by a system and committing to providing them**

- The function of a system is indeed subjective in the sense it arises from the relation between a stakeholder and a system
- This does not mean that the function yielded by a given construction can be anything the stakeholder wants it to be
- The construction imposes limits on the function

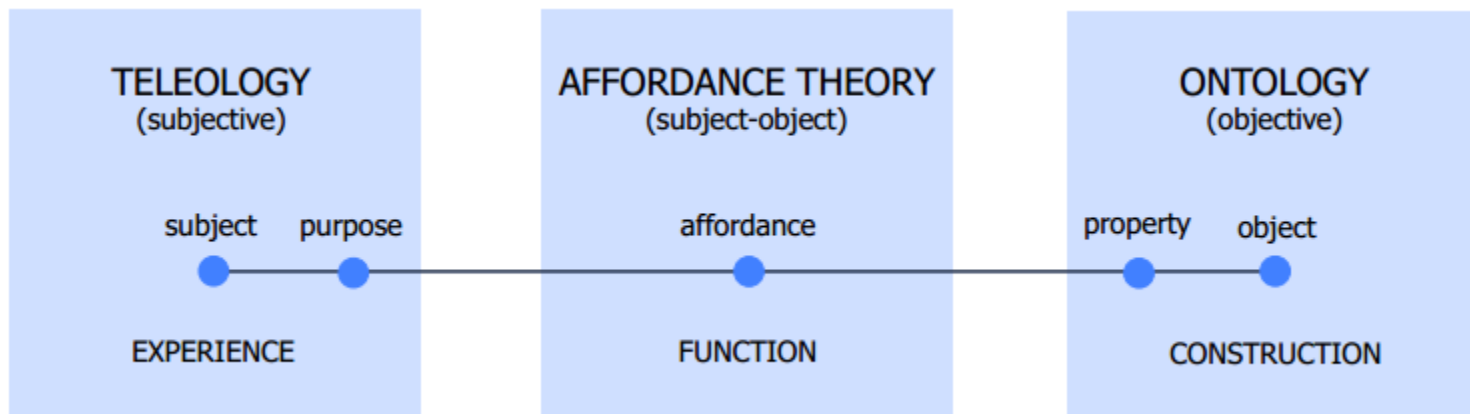

## (2) Value Exchange

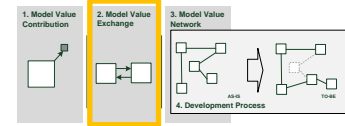

**Specifying why two actors (social systems) come together to interact**

The successful engagement of a pair of systems depends on two conditions:

1. their constructions must mutually fit (operational **feasibility**)
2. they must have mutual interest in value co-creation (**motivation**)

When combined, they support the belief that system A will deliver a solution to a problem of system B and the other way around.

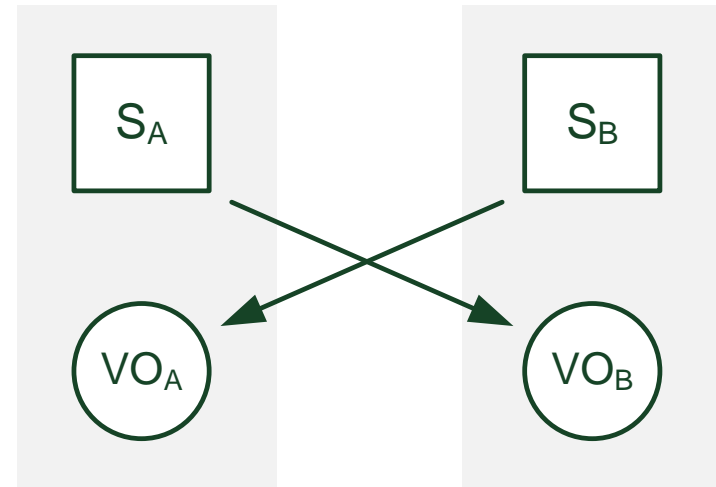

subject  $\langle S_A \rangle$  desires value object  $\langle VO_B \rangle$

subject  $\langle S_B \rangle$  desires value object  $\langle VO_A \rangle$

# (2) Value Exchange

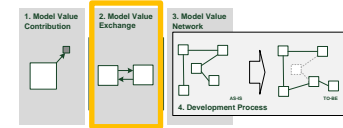

## e3Value

- Ontological approach for modelling **networked value constellations**
  - Directed towards e-commerce
  - Creation, exchange and consumption of **economically valuable** objects
  - No construction support
- Introduces **value model deconstruction and reconstruction** [1]
  - Still, no structural support for a formal, content-based rationale for decisions
- Actors must be economically independent entities - constraint

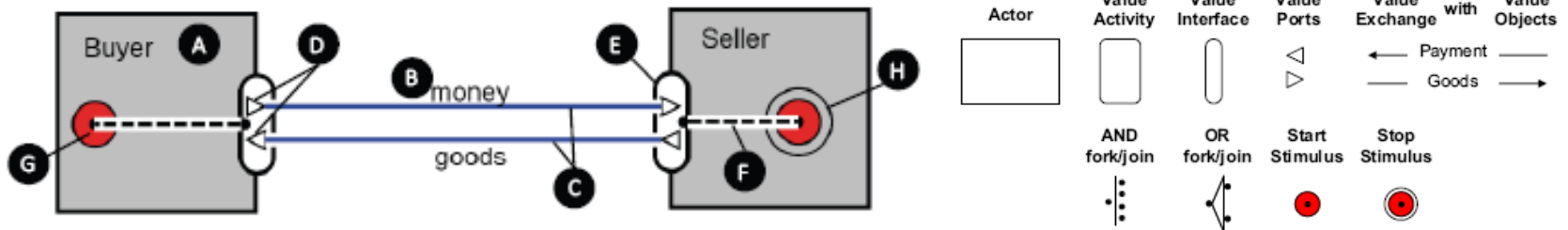

[1] Gordijn, J., Value-based requirements Engineering: Exploring innovatie e-commerce ideas. 2002, Vrije Universiteit Amsterdam: Amsterdam.

# DEMO and e3Value Matching Ontology

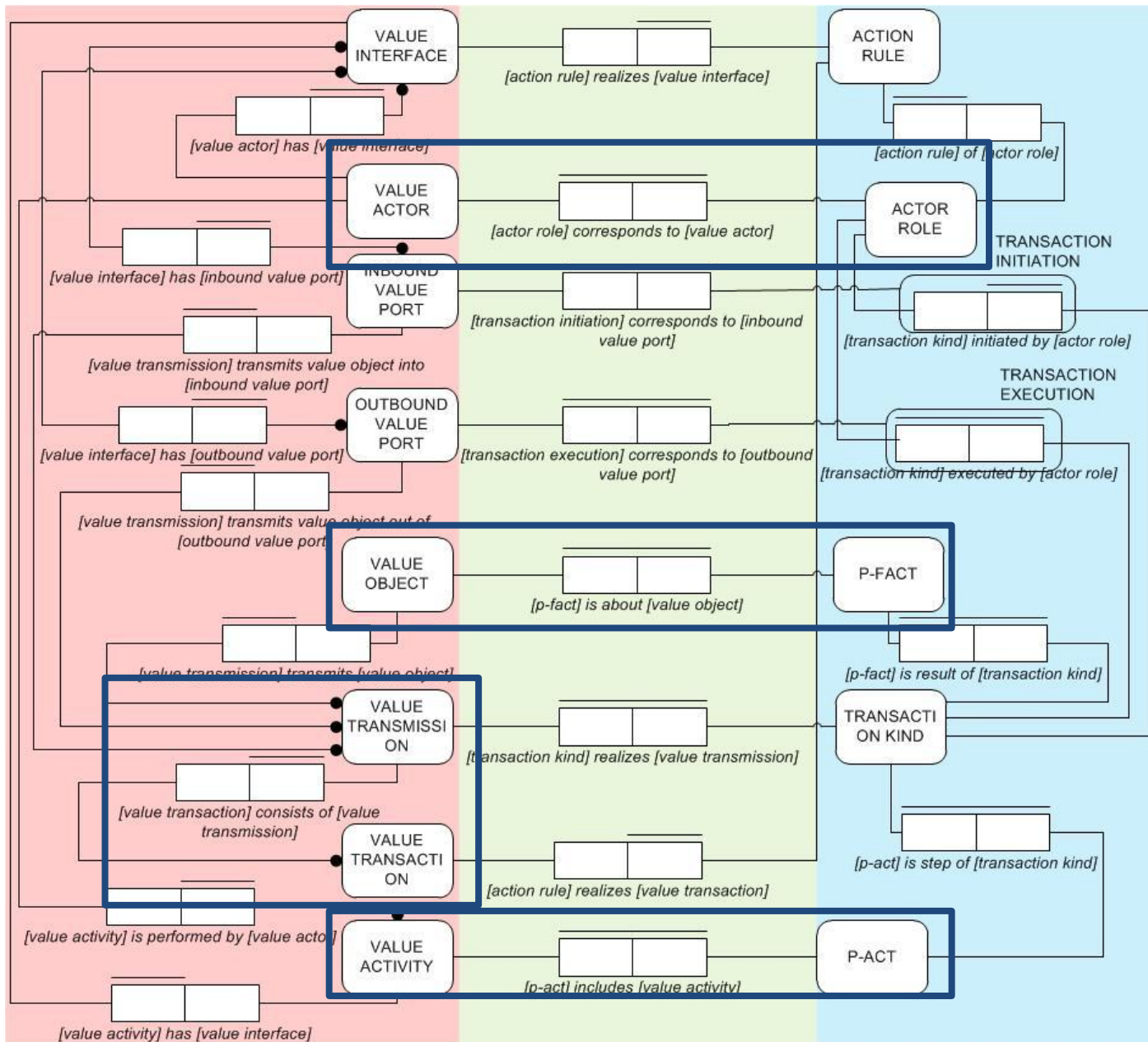

- Value Object
- Value Activity
- Value Actor
- Value Transaction

# Library Example – Revised Value Model

- *stock controller* contribution:
  1. Combining title demand information with stock to minimize loan declines due to unavailability
  2. Procuring demanded titles efficiently

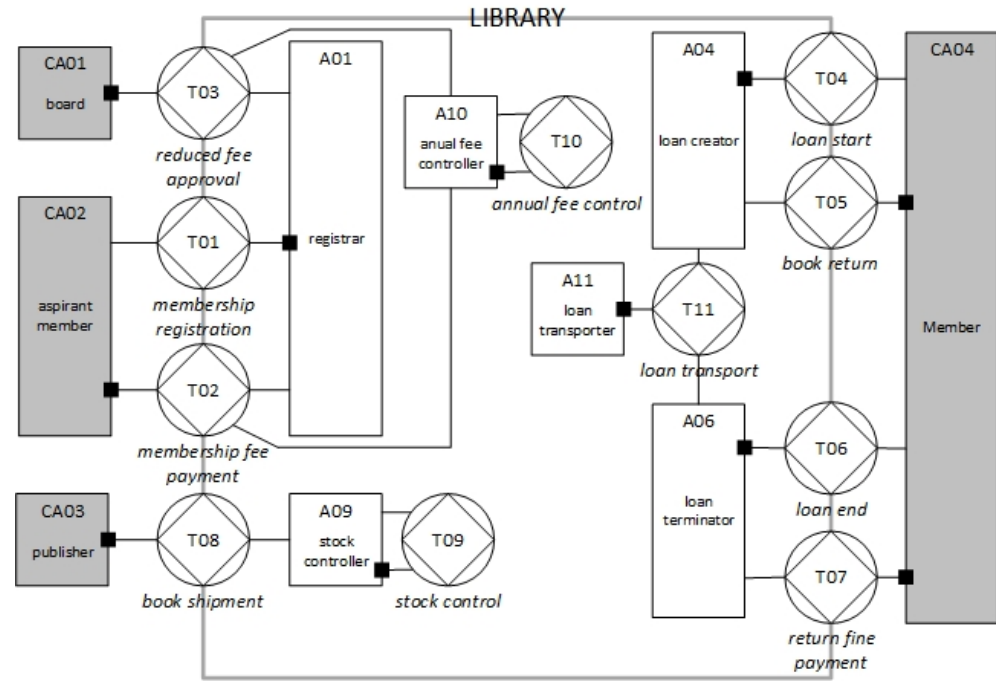
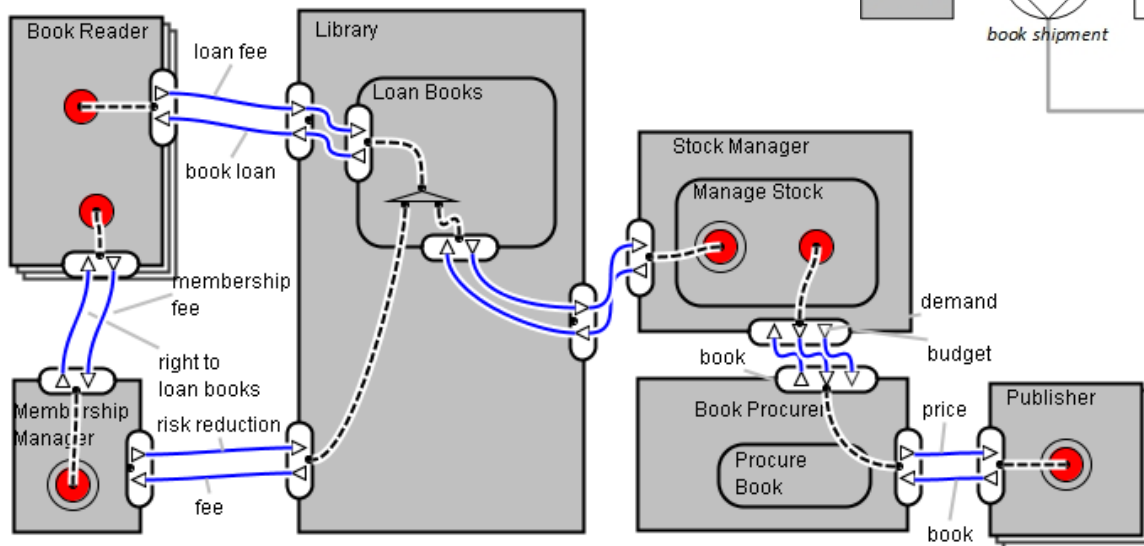

- *membership manager* role is about risk control, its contribution is now adequately isolated

# (3) Model Value Network

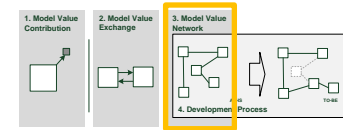

1. RESULT TREE (RT) - a tree of solutions or results that will converge, in the root, as solution for a certain problem the consumer has
2. Namely she requires a certain object – class VALUE OBJECT (VO) – for her activity
3. In turn, the object provided will be generated by a certain activity – class VALUE ACTIVITY (VA) – which in turn will require one or more objects and so on
4. In our ontology we specify classes REQUIRE LINK (RL) and GENERATE LINK (GL)
5. A **Value Network** is composed of a set of result trees with at least one value actor (performing a VA) shared between each tree and the rest of the network

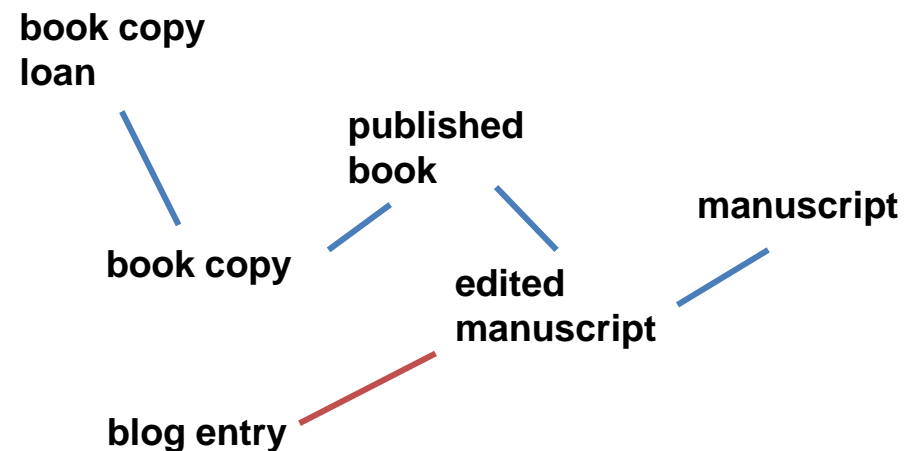
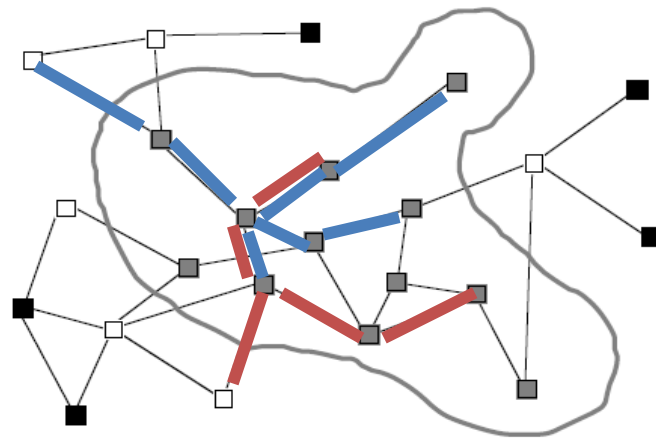

# Value Network Ontology

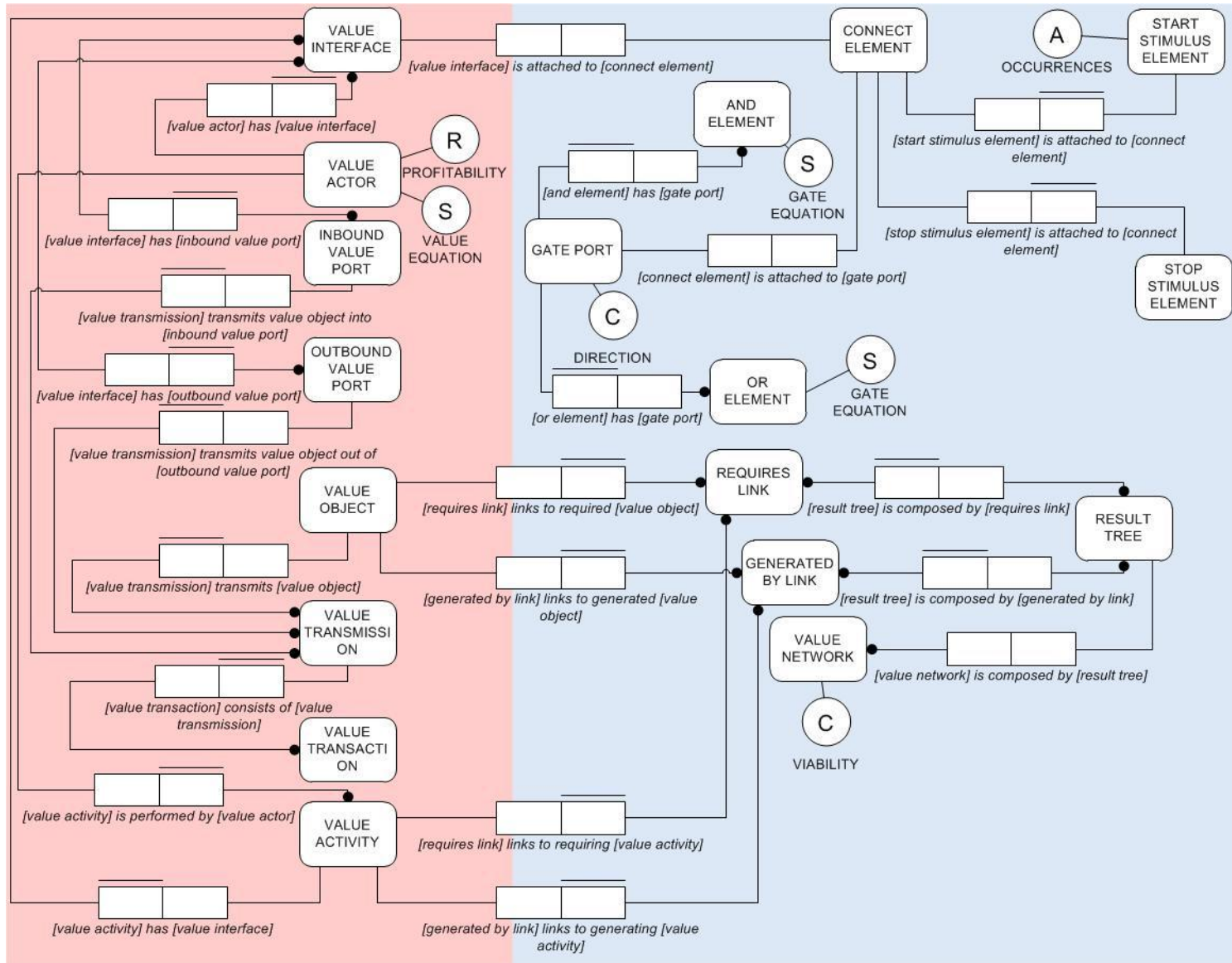

# Integrated Model Qualities

1. **Value Object completeness** – for each actor, every outbound VO must either be inbound or be generated/transformed inside through a value activity
2. **Transaction completeness** – the acts and facts of the complete transactional pattern are fully specified
3. **Value exchange constructability** – for each value exchange, the corresponding ontological transaction 1) exists and 2) is fully specified (2)
4. **Transaction justifiability** – for each ontological transaction, the corresponding value exchange 1) exists and 2) is complete (1)
5. **Economical reciprocity** – the dependencies between the ontological transactions that constitute a value transaction are defined via Action Rules
6. **Valuation** – for each actor, the valuation of value ports, the Investment and the Expenses are defined
7. **Implementability** – there is an actor to instantiate each actor role (value port structure) according to its valuation specification
8. **Viability** – every value actor belonging to the composition of a value network is viable in the value network configuration

# Viability - Value Equations

- From the value network specification, one can derive value equations that must be fulfilled by the implementation
- Each value actor has a characteristic value interface specification in the form of value equation determined by its value ports and their direction

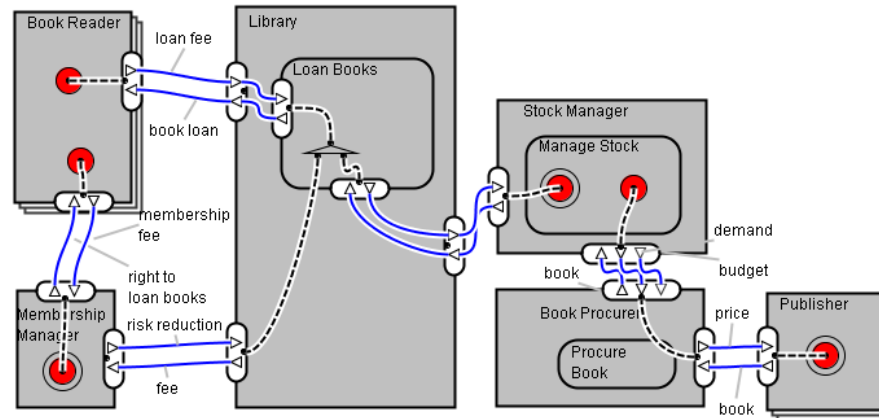

$V$  book reader

$$= \text{book loan} - \text{book loan fee} + \text{right to loan books} - \text{membership fee}$$

# Viability - Value Equations

A chain is as strong as its weakest link

- For a full network optimization in our example, we would need to solve the following set of equations to maximize profit of all the actors:

$$\left\{ \begin{array}{l} V \text{ book reader} = \text{book loan} - \text{book loan fee} + \text{right to loan books} - \text{membership fee} \\ V \text{ membership manager} = \text{risk reduction fee} - \text{insurance (risk reduction/transference)} + \text{membership fee} - \text{right to loan books} \\ V \text{ library} = \text{book loan fee} - \text{book copy loan} + \text{risk reduction} - \text{risk reduction fee} - \text{book stocking fee} + \text{book copy loan} \\ v \text{ stock manager} = \text{book} - \text{demand} - \text{budget} - \text{book} + \text{book stocking fee} \\ v \text{ book procurer} = \text{book} - \text{book price} - \text{book} + \text{demand} + \text{budget} \\ v \text{ publisher} = \text{book price} - \text{book} - \text{publishing costs} \end{array} \right.$$

- the value network is **viable** if the valuations of the value objects that make up the interfaces of each value actor in the **configuration** make them collectively viable according to the value equations
  - e.g. fair trade

# (4) Development Process

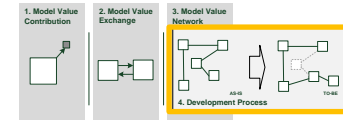

## Weaving the Value Network

- Value-oriented Solution Development Process (VoSDP)
- Solution Development Organization (SDO)

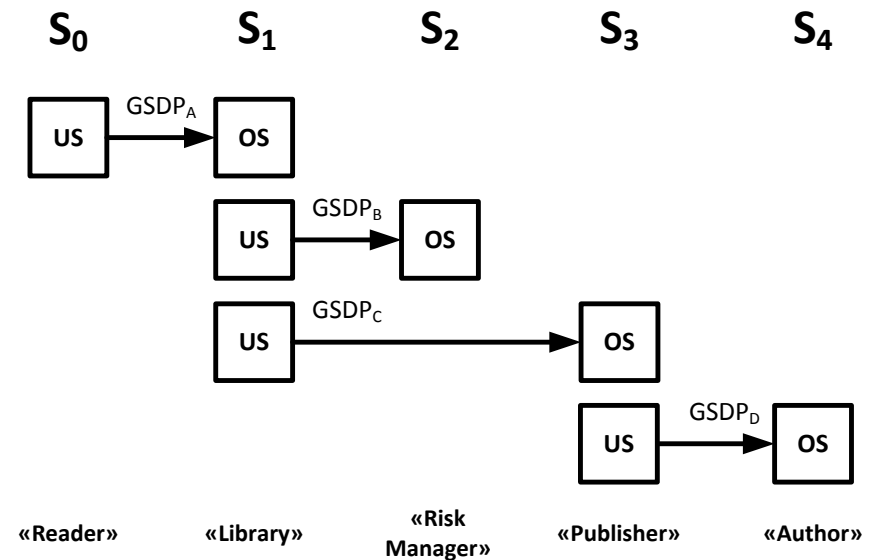

# Contributions & Conclusions

- **Integration of Teleological and Ontological perspectives**
  - Formal way of analyzing and improving alignment between systems
  - **Constructability** and **Justifiability**
- **Conceptual alignment and implementation of the two ontologies**
  - **VM**: value coherence, economic reciprocity, value specification of p-facts
  - **DEMO**: transactional completeness, *responsibility, authority* and *competence*
- **Addressing Change**
  - Specification of system binding rationale
  - Model system composition as a sequence of value-oriented solutions
  - Essential Value Model for expressing purpose and relation towards construction

Contacts:

[jpombinho@gmail.com](mailto:jpombinho@gmail.com)

<http://www.linkedin.com/in/jpombinho>

Thank You!